

# SL3ICS31 01

## UCODE EPC 1.19 Functional specification

Rev. 3.0 — 6 July 2007  
093130

Preliminary data sheet  
PUBLIC

## 1. General description

---

The UCODE EPC 1.19 / SL3ICS31 01 IC is a dedicated chip for passive smart tags and labels, especially for supply chain management and logistics applications for worldwide use with especial consideration of European and US regulations to ensure that operating distances of several meters can be realized.

This integrated circuit is the result of a development study for the "OID Radio Frequency Identity Protocols, Generation 2 Identity Tag (Class 1): Protocol for Communications at 860 MHz – 960 MHz" in support of the referred specification's major features of Manchester coding on the reader to tag link and FM0 coding on the tag to reader link. Further, it supports basic modules of the anticollision, command set and memory structure. However, it does not support any mode to permanently disable the tag, respectively tag IC.

The tag requires no internal power supply. Its contactless interface generates the power supply via the antenna circuit by propagative energy transmission from the reader.

## 2. Features

---

### 2.1 RF interface features

- Contactless transmission of data and supply energy (no battery needed)
- Operating distance, depending on antenna geometry and local regulations, up to 8.4 m for a single antenna
- Operating frequency within the released operating bands from 860 MHz to 960 MHz and from 2.4 GHz to 2.5 GHz
- High data integrity: 16 bit CRC, framing
- Anticollision / Tag inventory speed of:
  - Around 100 tags/s - with data rate of 40/160 kbits/s applicable for US and targeted future EU regulations
  - Around 50 tags/s - with data rate of 40/40 kbits/s for current EU regulations.

### 2.2 Memory features

- 64 and 96 bits EPC numbers supported
- 256 bits user memory
- Persistent ID flag

### 2.3 Security features

- Lock mechanism (write protection) for each byte

## 2.4 Air interface standards

The SL3ICS31 01 supports major parts of the "OID Radio Frequency Identity Protocols, Generation 2 Identity Tag (Class 1): Protocol for Communications at 860 MHz – 960 MHz":

- Manchester coding on the reader to tag link
- Data rate and waveform options to support both European and US regulations on the reader to tag link
- FM0 coding on the tag to reader link
- Data rate and data rate multipliers to support both European and US regulations on the tag to reader link
- Anticollision basics
- Command set basics
- Persistent ID flag

## 3. Ordering information

---

[See wafer specification of device](#)

## 4. Block diagram

The SL3ICS31 01 IC consists of three major blocks:

Analog RF Interface

Digital Controller

EEPROM

The analog part provides stable supply voltage and demodulates data received from the reader for processing by the digital part. Further, the modulation transistor of the analog part transmits data back to the reader.

The digital section includes the state machines, processes the protocol and handles communication with the EEPROM, which contains the EPC and the user data.

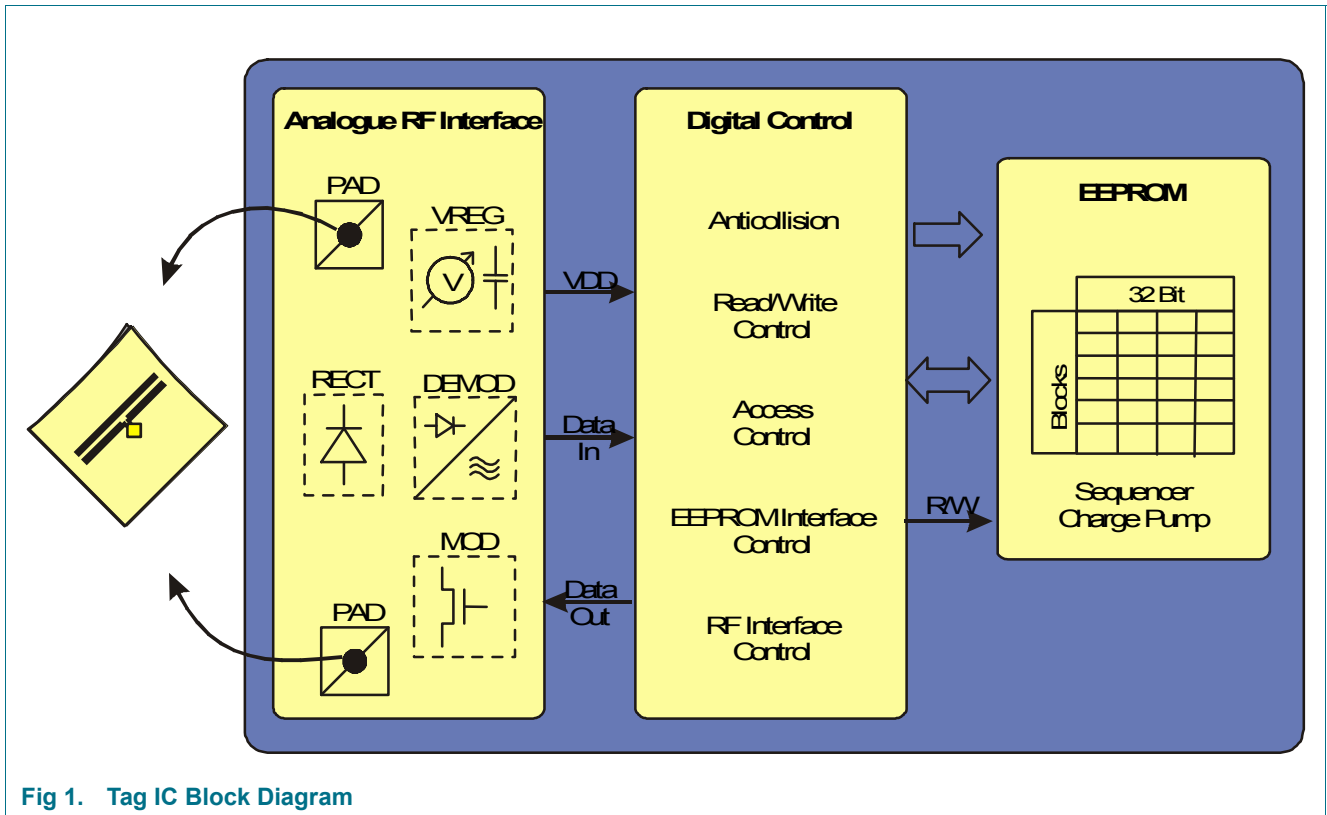

Fig 1. Tag IC Block Diagram

## 5. Function description

### 5.1 Power transfer

The reader provides a RF field that powers the tag, which contains the SL3ICS31 01 and an antenna. The tag antenna transforms the impedance of free space to the chip input impedance in order to get the maximum possible power for the SL3ICS31 01 on the tag.

The RF field, which is oscillating on the operating frequency provided by the reader, is rectified to provide smoothed DC voltage to the analog and digital modules of the IC.

The antenna that is attached to the chip has to support the rectifier structure on the chip by having no short circuit between the two antenna connectors (e.g. simple dipole structure), as a DC voltage will appear on the chip inputs during chip operation.

The RF field has to be turned on whenever the tag should operate. This also includes response time (backscatter) and the EEPROM programming process.

### 5.2 Operation frequency

The SL3ICS31 01 supports global operation in different frequency bands. In principle, the SL3ICS31 01 has no restriction on the operating frequency. Based on regulation requirements the SL3ICS31 01 is released for the following frequency bands.

Table 1.

FREQUENCY BAND	LOWER LIMIT	UPPER LIMIT	UNIT
UHF	860	960	MHz
2.45 GHz	2.4	2.5	GHz

### 5.3 Data transfer

#### 5.3.1 Reader to tag link

On the reader to tag link the SL3ICS31 01 supports Manchester Code amplitude modulation. For data transmission, the reader switches between 2 values of emitted power.

Details are described in chapter Physical layer and signaling.

#### 5.3.2 Tag to reader link

As the energy of the RF field is used and required for operation, the tag communicates back to the reader by changing its load to the RF field. For high frequencies, the behavior of the RF field (electromagnetic field) may be described by traveling waves. Therefore, this method is called backscatter.

Details are described in chapter Physical layer and signaling.

## 6. Physical layer and signaling

The physical layer is the air interface between reader and tag, including signaling frequencies, modulation, data coding, RF envelope, data rates, and other parameters as are required to ensure reliable communications.

Tags collect their operating power from a reader's RF field. Readers send information to tags by modulating the RF carrier. They receive information from tags by transmitting an unmodulated RF carrier and listening for a tag's backscattered reply.

The air interface between reader and tag is half-duplex. The SL3ICS31 01 does not demodulate reader commands while backscattering.

A reader's RF stage can be in one of three possible states:

- Emitting no RF energy.
- Emitting modulated RF energy, to communicate with one or more tags.
- Emitting unmodulated RF energy, to (1) provide power to one or more tags, and (2) provide an RF field for backscatter signaling by the tags.

Readers communicate information to tags using Manchester encoding. Tags backscatter information to readers use baseband FM0. These encoding formats are described in detail in chapters [Section 2.1](#) and [Section 6.2.1](#).

### 6.1 Reader to tag communication

The tag front end effectively filters out short power interruption. Longer power interruptions will be detected and are interpreted as communication, tag writing, or, if exceeding a certain criteria in duration, may generate a tag reset (see [Section 6.3.6](#)).

If tag power is to be maintained between commands, the reader field must be kept on. If power is interrupted within  $t_{SD}$  (as if might happen during reader frequency hops from one channel to another), the tag may interpret the hop event as the beginning of the PREAMBLE field. The tag will not succeed to decode the first command that follows the hop. If a data stream with 10 closely spaced rising edges (i.e. 10 Manchester 0's) is sent to the tag immediately after a known brief power interruption event, however, the first command following the event will be decoded (that command must start with the PREAMBLE\_DETECT field). The sequence that provides the ten rising edges to the tag is called RESYNC.

**Table 2. Definition of tag RESYNC**

	NRZ CODED DATA STREAM
TAG RESYNC	01 01 01 01 01 01 01 01 01 01

In order for a write to be successful, tag power must be maintained throughout the  $t_{EWrite}$  execution time. Furthermore, the on-chip supply voltage required for a successful write is higher than that required for a successful read (this asymmetry causes the asymmetry between tag read and write ranges). Power interruptions during the write cycle may be unavoidable in difficult operating environment, however, resulting in corrupted or unreliable data. The VERIFY command is used to identify bad data immediately after the WRITE or LOCK process so that it can be rewritten. – Please, see [Section 6](#) for details regarding those commands.

6.1.1 Modulation

Readers communicate with tags using ASK modulation, as shown in [Figure 2](#). The modulation depth (depth of the RF dip relative to the unmodulated carrier) is either 30% or 100%.

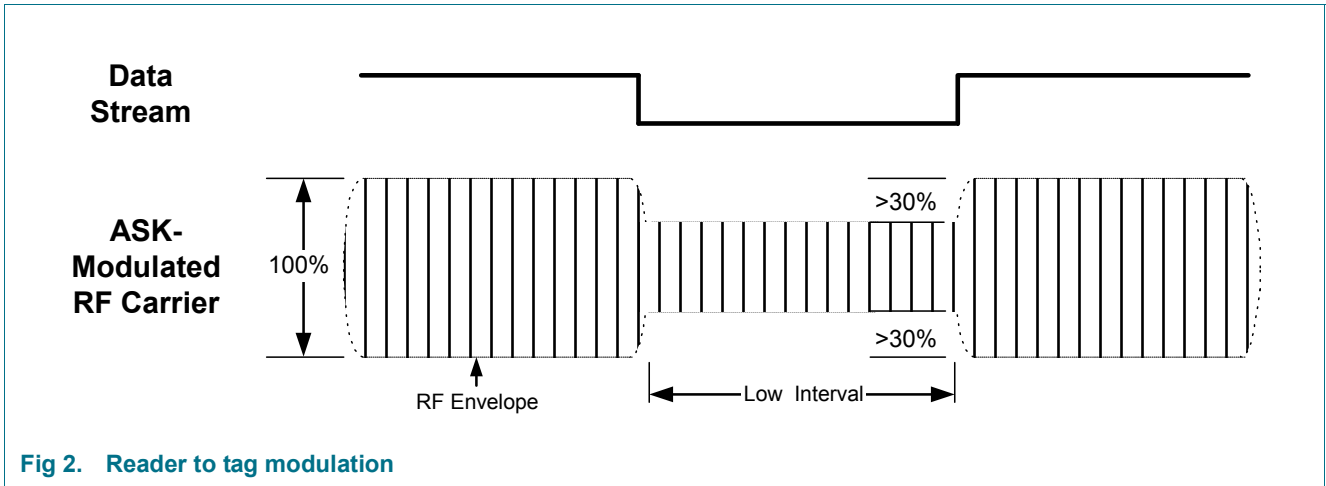

Fig 2. Reader to tag modulation

6.1.2 Data Coding

The reader to tag link uses Manchester encoding, shown in Figure 3. The duty cycle (ratio of high to low cycle time) is according Table 3.

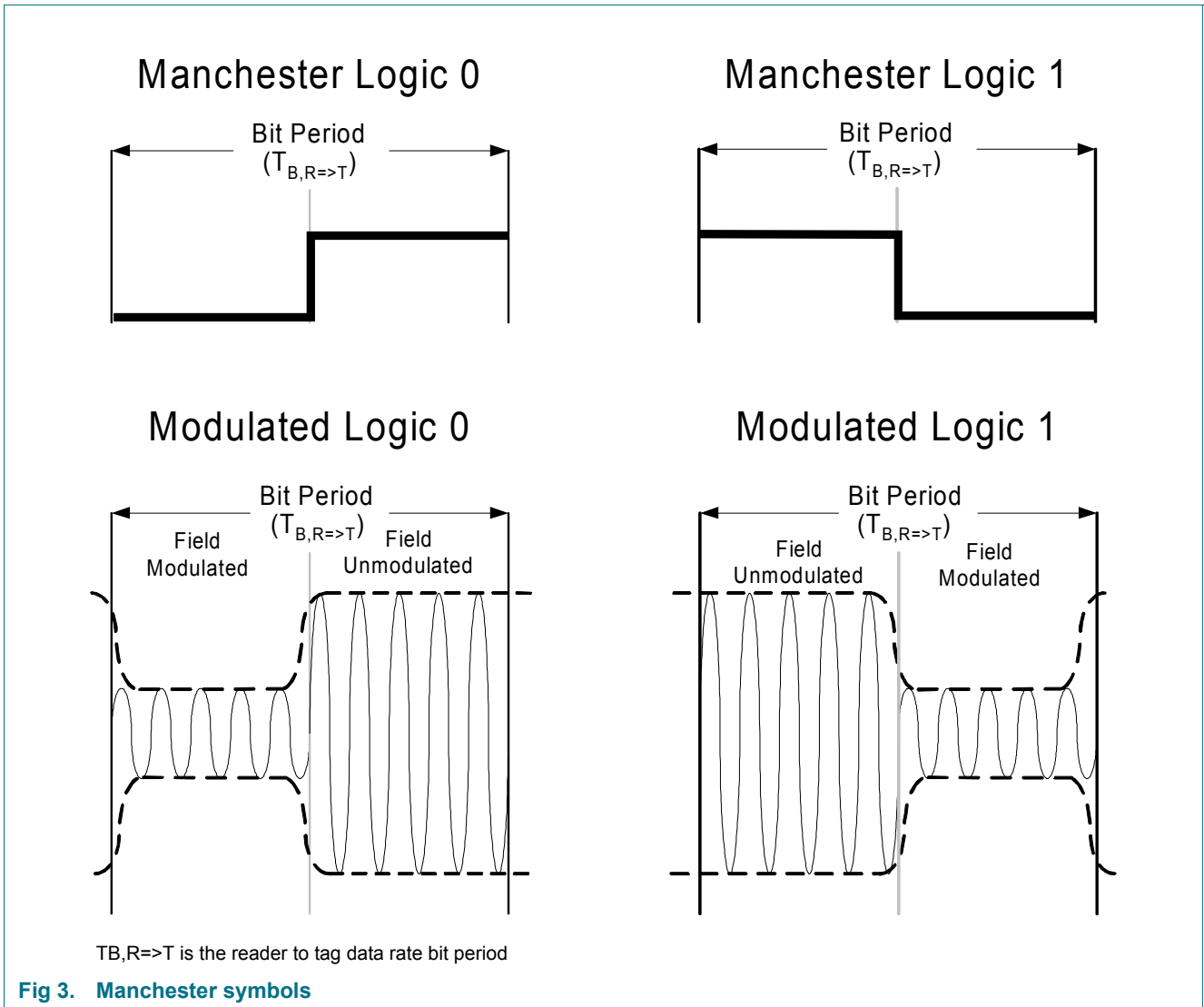

Table 3. Manchester reader to tag link bit duty cycle tolerance

	MIN	TYP	MAX	UNIT
Reader to tag bit duty cycle	45	50	55	%

6.1.3 RF Envelope

The SL3ICS31 01 waveform is defined in [Figure 4](#). The values defined as “A” in [Figure 4](#) is the maximum amplitude of the RF envelope. The value “B” defined in [Figure 4](#) is always smaller than “A”.

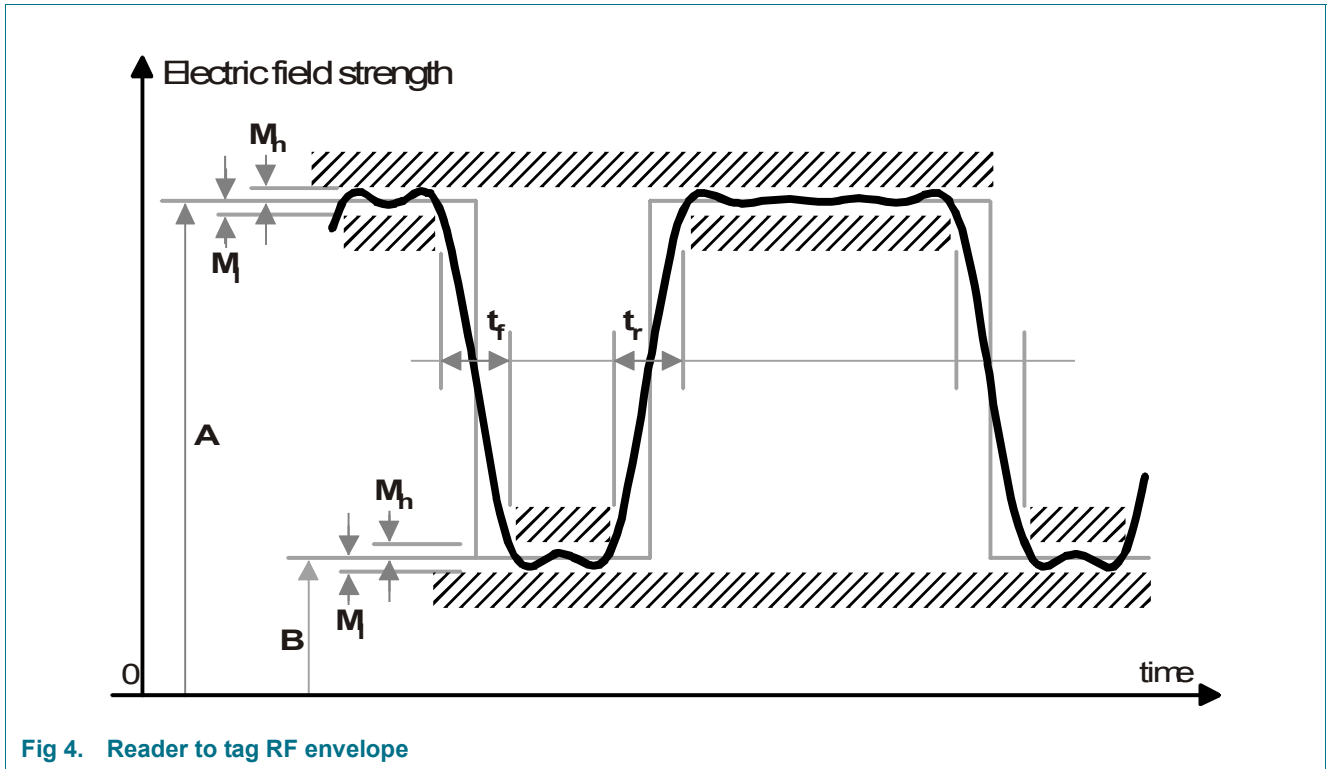

Fig 4. Reader to tag RF envelope

Table 4. RF envelope parameters

MODULATION	DATARATE	PARAMETER	SYMBOL	MIN	TY P	MAX <sup>[1]</sup>	UNITS
Shallow	40 kbps	Modulation Depth	$(A-B)/A$	26	30	33	%
		RF Envelope Ripple	$M_h = M_l$	0		0.05 (A-B)	
		RF Envelope Rise Time	$t_{r,10-90\%}$	0		0.17	s
		RF Envelope Fall Time	$t_{f,10-90\%}$	0		0.17	s
						$T_{B,R \Rightarrow T}$	
Deep	40 kbps	Modulation Depth	$(A-B)/A$	95		100	%
		RF Envelope Ripple	$M_h = M_l$	0		0.03 (A-B)	
		RF Envelope Rise Time	$t_{r,10-90\%}$	0		0.1	s
		RF Envelope Fall Time	$t_{f,10-90\%}$	0		0.1	s
						$T_{B,R \Rightarrow T}$	

[1]  $T_{B,R \Rightarrow T}$  is the reader to tag data rate bit period



6.1.4 Preamble

Reader to tag signaling begins with a preamble comprising nine leading “0” bits, and some bits containing a Manchester high violation. The frequency of the leading “0” bits determines the reader to tag data rate.

Table 5. Definition of read to tag PREAMBLE

TAG TO READER MULTIPLIER	NRZ CODED DATA STREAM
1x	01 01 01 01 01 01 01 01 01 11 00 11 10 10
4x	01 01 01 01 01 01 01 01 01 11 01 11 00 10 1

6.2 Tag to reader communication

A tag communicates with a reader using backscatter modulation, in which the tag changes the reflection coefficient of its antenna between two states in accordance with the data being sent.

6.2.1 Modulation and data coding

Tags transmit information to readers using either baseband modulation using FM0 encoding.

6.2.1.1 Baseband FM0

Figure 5 shows FM0 (Bi-Phase Space) encoding. The duty cycle of the backscattered modulation is according Table 6.

FM0 encoding has memory. Consequently, the choice of FM0 sequences in Figure 5 depends on prior transmissions.

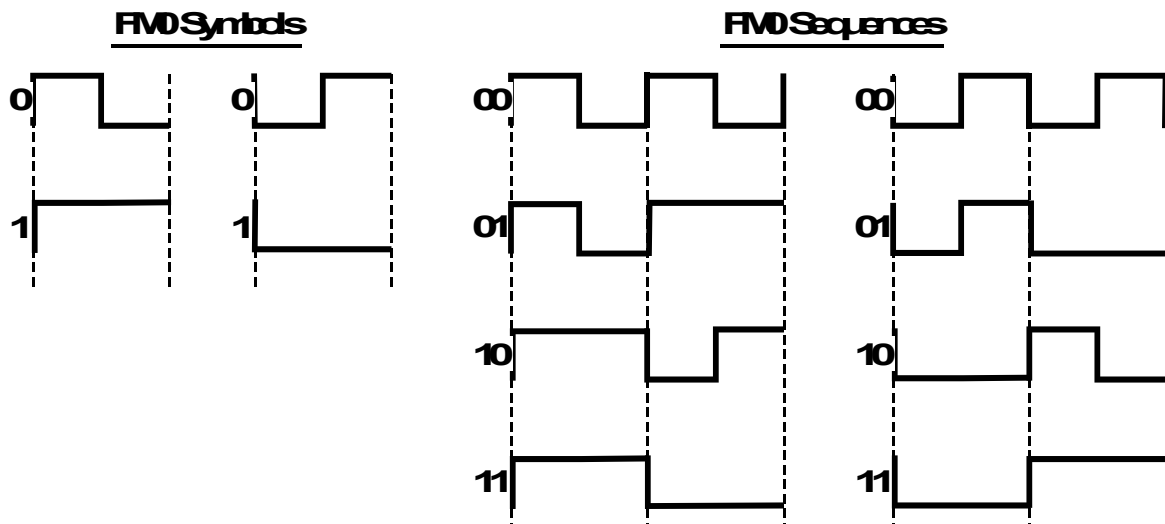

Fig 5. FM0 symbols and sequences

**Table 6. FM0 tag to reader link bit duty cycle tolerance**

	MIN	TYP	MAX	UNIT
Tag to reader bit duty cycle	40	50	60	%

### 6.2.1.2 FM0 Preamble

Tag to reader FM0 signaling begins with a preamble comprising four leading “0” bits, an FM0 violation, and a trailing “0”.

**Table 7. Definition of tag to reader preamble**

	NRZ CODED DATA STREAM
Tag to reader PREAMBLE	00 00 01 01 01 01 01 01 01 01 00 01 10 11 00 01

### 6.2.2 Data rates

The SL3ICS31 01 supports tag to reader datarates as specified in [Table 8](#).

**Table 8. FM0 Reader to tag link datarates**

READER TO TAG DATARATE	TAG TO READER MULTIPLIER	TAG TO READER DATARATE	FREQUENCY TOLERANCE
40 kbps	×1	40 kbps	+/- 15%
	×4	160 kbps	+/- 15%

## 6.3 Link timing

### 6.3.1 Reader to tag link

Every command starts with a command header consisting of PREAMBLE\_DETECT and a PREAMBLE. In this document, the appearance of these sequences is given in NRZ format. A NRZ ‘1’ means maximum field strength and NRZ ‘0’ means lower or even zero field (see also [Section 6.1](#)). Compared to the Manchester coded data, these sequences are given in halfbits.

All other transmitted data will be defined Manchester coded. This means that the digital data will be defined by a falling or rising transition in the middle of the bit. Furthermore, this means that a Manchester coded bit can be defined by two halfbits of a NRZ code.

The reader to tag link consists of the following sequences:

- PREAMBLE\_DETECT  
no transition allowed during this time
- PREAMBLE  
tag calibrates onto reader to tag data rate and tag verifies ist calibration
- COMMAND (CMD)  
Address + Byte Mask + Data only if required by the command
- CRC – 16  
16 check bits, calculated from COMMAND + Address + Byte Mask + Data
- WAIT  
only if COMMAND was a WRITE, to power the tag during EEPROM write

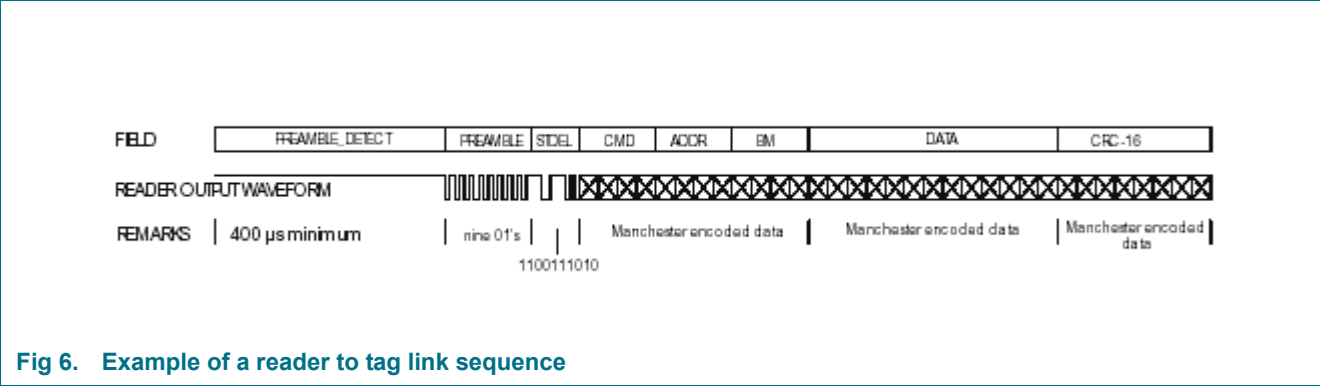

Fig 6. Example of a reader to tag link sequence

### 6.3.2 Tag to reader link

A tag to reader link header consists of QUIET and RETURN\_PREAMBLE. Just like the reader to tag link header, this will be defined via NRZ coding. Here a NRZ '1' means that the IC shortens the input pins. A NRZ '0' does not affect the chip input impedance (see also in [Section 6.2 "Tag to reader communication"](#)).

Tag to reader data will be encoded in FM0. This means that on every edge of a bit a transition will occur. Adding or not adding a transition in the middle of the bit will encode the digital data. One FM0 bit is defined by 2 NRZ halfbits.

The tag to reader link consists of the following sequences, and starts immediately after the end of the reader to tag link:

- QUIET  
no transition allowed during this time
- RETURN PREAMBLE  
reader calibrates onto tag to reader data rate
- DATA  
tag to reader data
- CRC – 16  
16 check bits

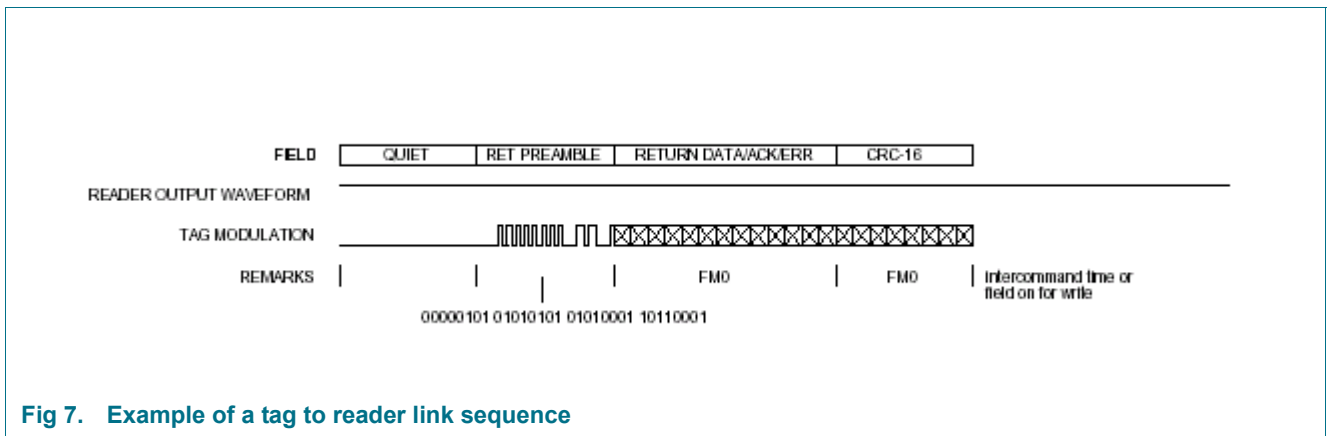

Fig 7. Example of a tag to reader link sequence

### 6.3.3 Response time

The tag immediately starts sending back the tag to reader sequence after a correct command was received. As this sequence starts with a QUIET field (see Section 5.6.2) the reader may use the time for that field for settling its receiver section.

Table 9. Maximum reader settling time

QUIET field length
16 · Tag to reader to tag bit rate - 0.75 · Trader to tag bit rate

### 6.3.4 Regeneration time

After a response of the tag or the end of a WAIT field, the tag is immediately able to receive a new command sequence from the reader. This sequence will again start with a PREAMBLE\_DETECT field.

### 6.3.5 Start-up time

In general no special rise time is required. However, before starting data transmission to the tag, the reader has to establish a permanent carrier. If the begin of ramp up of the field as starting time of a new command is used (as may desired after a frequency hop, to shorten the communication time), the values defined in figure [Figure 8](#) and [Table 10](#) apply.

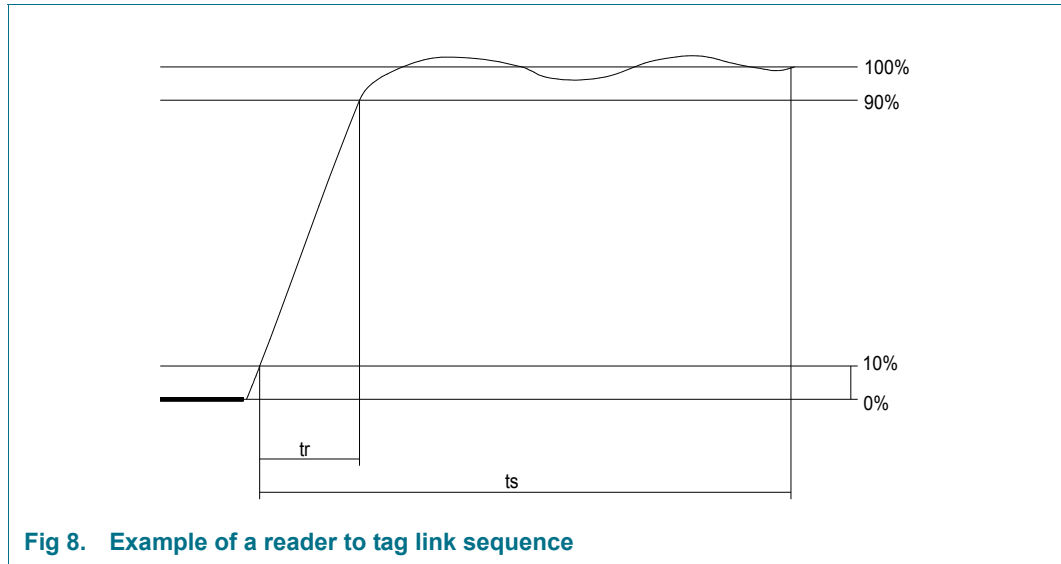

Fig 8. Example of a reader to tag link sequence

Table 10. Timing limits

SYMBOL	MIN	TYP	MAX	UNIT
$t_r$	0		30	$\mu\text{s}$
$t_s$	400			$\mu\text{s}$

### 6.3.6 Power interruptions

Power interruptions of different times will lead to the following consequences:

Table 11. Tag reaction on power interruptions

POWER INTERRUPTION TIME: $t_{\text{interrupt}}$	CONSEQUENCES	
FROM	TO	
0	$t_{\text{NN}}$	No notice of interruption by the tag
$t_{\text{NN}}$	$t_{\text{SD}}$	Start of demodulation by the tag due to the power interrupt may happen, if the tag is not reset due to power shortage.
$t_{\text{SD}}$	$t_{\text{ID}}$	The persistent flag ID stays valid. All other flags and the digital state information is lost.
$t_{\text{ID}}$		Tag loses all internal flag and state information and the persistent flag ID is reset as well.

### 6.4 Bit and byte ordering

In all byte fields, the most significant bit (MSB) is transmitted first, proceeding to the least significant bit (LSB).

In all WORD\_DATA (8 byte) or BLOCK\_DATA (4 byte) data fields, the most significant byte is transmitted first.

The most significant byte is the byte at the specified address. The least significant byte is the byte at the specified address plus 7 or plus 3. That is, bytes are transmitted in incrementing address order.

The MSB of the byte mask corresponds to the most significant data byte, the byte at the specified address.

The byte mask for WRITE and VERIFY uses only 4 bits. The MSB corresponds to the most significant byte that should be written. The 4 unused LSBs in the byte mask are ignored.

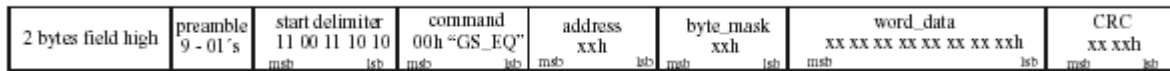

Fig 9. Example of a reader to tag link sequence

### 6.5 Data integrity

There are two types of transmission errors: modulation coding errors (detectable per bit) and CRC errors (detectable per command). Both errors cause any command to be aborted. The tag does not respond. For all CRC errors, the tag returns to the READY state. For all coding errors, the tag returns to the READY state if a full valid preamble had been detected. Otherwise, it maintains in its current state.

### 6.6 CRC definition

The CRC-16 is calculated according the CRC-CCITT standard polynomial  $X^{16} + X^{12} + X^5 + 1$ . The Cyclic Redundancy Check (CRC) is calculated on all data contained in a message, from the start of the command through to the end of data. This CRC is used from reader to tag and from tag to reader.

On receiving a command from the reader, the tag verifies if the checksum or the CRC value is valid. If it is invalid, it discards the frame and does neither respond, nor take any other action.

Table 12. CRC definition

CRC type	Length	Polynomial	Direction	Preset	Residue
CRC-CCITT	16 bits	$X^{16} + X^{12} + X^5 + 1$	Reader to tag and tag to reader link	'FFFF'	'0'

### 6.6.1 CRC Algorithm

For computing the CRC:

- Initialize the CRC accumulator to all ones - FFFFhex
- Accumulate data using the polynomial  $X^{16} + X^{12} + X^5 + 1$
- Invert the resulting CRC value
- Attach the inverted CRC-16 to the end of the packet and transmit it MSB first

For checking the CRC:

- Compute the CRC on the incoming packet
- Accumulate the inverted CRC in the CRC registers
- Verify that the accumulator is all zeroes

An example for the CRC calculation is given in the following section.

### 6.6.2 CRC calculations example

This example refers to a SCROLL command.

SCROLL command code: '09 hex or 00001001b'.

The packet sent from the reader to the tag consists of the following blocks, but only the SCROLL command (09hex), is used in the CRC calculation.

The CRC is calculated on the SCROLL command as the field is transmitted MSB first.

The following example shows the values of the 16 CRC registers as the data is shifted through the CRC registers.

**Table 13. Practical example of CRC calculation for a 'SUCCESS' command in the reader**

STEP IN READER	INPUT (SUCCESS CMD)	CALCULATED CRC
1	0	'EFDf'
2	0	'CF9F'
3	0	'8F1F'
4	0	'0E1F'
5	1	'0C1F'
6	0	'183E'
7	0	'307C'
8	1	'70D9'

Table 14. Practical example of CRC checking for a 'SUCCESS' command in the tag

STEP	INPUT (SENT CRC-16)	CALCULATED CRC IN TAG
0		'70D9'
1	0	'E1B2'
2	1	'C364'
3	1	'86C8'
4	1	'0D90'
5	0	'1B20'
6	0	'3640'
7	0	'6C80'
8	0	'D900'
9	1	'B200'
10	1	'6400'
11	0	'C800'
12	1	'9000'
13	1	'2000'
14	0	'4000'
15	0	'8000'
16	1	'0000'

## 7. TAG identification and transaction

This chapter contains all information including commands by which a reader selects, inventories, and accesses a tag population. Tags that enter an energizing RF field and have sufficient power for operation wait in a READY state until receiving a SELECT command from a reader to move them into the SINGULATION state. As no tags reply without first receiving a SELECT command, the protocol is consistent with Reader-Talks-First (RTF) operation. All commands begin with the preamble described in chapter Preamble.

The communication between reader and tag consists of 3 major parts:

- A reader first uses the SELECT command to place a tag population into the SINGULATION state.
- A reader than may exclude certain tags from the inventorying by use of the commands UNSELECT\_ID\_FLAG, UNSELECT\_NOID\_FLAG, UNSELECT\_NE
- A reader then inventories tags. The reader begins an interrogation round by transmitting a QUERY command and uses QUERY and SCROLL commands until it has singulated one tag.
- After identifying a single tag, the reader may continue to get other tags with a SCROLL command and goes back to step 2.
- After identifying a tag, the reader has the option to access it with read, write and lock commands.



## 7.1 Tag overview

### 7.1.1 State and flags

The SL3ICS31 01 implements the states READY, SINGULATION and INVENTORIED.

#### 7.1.1.1 Ready

The tag enters the READY state upon entering an energizing RF field. It resets all non-persistent internal states and awaits a SELECT command. Only the persistent flag ID is not reset, but determined by ist history.

#### 7.1.1.2 Singulation

The tag enters the SINGULATION state after a SELECT command. In case the tag stays powered, it stays in the SINGULATION state for collision arbitration. When identified the tag is moved from SINGULATION state to INVENTORIED state with an e.g. read command. In case the tag loses power, it returns to the READY state upon regaining power.

#### 7.1.1.3 Inventoried

When the tag enters the INVENTORIED state it sets ist ID (Identified) flag to indicate that is has been inventoried.

The tag retains ist ID flag for a minimum time of tID in the event of power loss (See chapter Power interruptions and chapter AC CHARACTERISTICS for details). However, the ID flag can also be cleared by a RESET command that causes the tag to reset the ID flag and additionally change to the READY state. A tag being in the INVENTORIED state may be used for data exchange data between tag and reader by read and write commands.

## 7.2 Tag memory

A SL3ICS31 01 based tag has 3 memory sections.

### 7.2.1 Reserved memory

The reserved memory is not accessible by the user. It is vendor specific and the data content is not defined. It also contains the lock information for the other memory sections.

### 7.2.2 System memory

This memory contains the EPC. It begins at address 00<sub>hex</sub>.

### 7.2.3 Memory overview

Table 15. SL3ICS31 memory

ADDRESS <sup>[5]</sup>	TYPE	CONTENT	INITIAL <sup>[1]</sup>	REMARK
00 <sub>hex</sub> – 01 <sub>hex</sub>	System	Tag header number	EF <sub>hex</sub> 04 <sub>hex</sub>	locked memory
02 <sub>hex</sub>	System	Portion of EPC <sup>[2]</sup>	02 <sub>hex</sub>	unlocked memory
03 <sub>hex</sub> – 07 <sub>hex</sub>	System	Portion of EPC <sup>[2]</sup>	unique number	unlocked memory
08 <sub>hex</sub> – 0F <sub>hex</sub>	System		Undefined <sup>[3]</sup>	unused

Table 15. SL3ICS31 memory

ADDRESS <sup>[5]</sup>	TYPE	CONTENT	INITIAL <sup>[1]</sup>	REMARK
10 <sub>hex</sub> – 17 <sub>hex</sub>	System	Portion of EPC <sup>[2]</sup>	all 00 <sub>hex</sub>	unlocked memory
18 <sub>hex</sub> – 37 <sub>hex</sub>	User	User defined	Undefined <sup>[3]</sup>	256 bit user memory, unlocked
38 <sub>hex</sub> - FF <sub>hex</sub>	RFU <sup>[4]</sup>	RFU <sup>[4]</sup>	Undefined <sup>[3]</sup>	

[1] This is the initial memory content when delivered by NXP

[2] See Application note 'IMPLEMENTATION OF EPC TAG DATA ON UCODE EPC 1.19' for details

[3] Reading this memory area delivers an undefined result

[4] RFU = Reserved for Future Use

[5] The memory at address 00hex - 07hex is labeled as SNR field

### 7.2.3.1 Supported EPC types

The EPC types are defined in the EPC™ Tag Data Standards document from EPCglobal®.

These standards define completely that portion of EPC tag data that is standardized, including how that data is encoded on the EPC tag itself (i.e. the EPC Tag Encodings), as well as how it is encoded for use in the information systems layers of the EPC Systems Network (i.e. the EPC URI or Uniform Resource Identifier Encodings).

The EPC Tag Encodings include a Header field followed by one or more Value Fields. The Header field defines the overall length and format of the Values Fields. The Value Fields contain a unique EPC Identifier and optional Filter Value when the latter is judged to be important to encode on the tag itself.

**A description and the memory mapping for 64 and 96 Bit EPC™ types can be found in the application note 'Implementation of EPC Tag data on UCODE EPC 1.19'.**

### 7.3 Tag state diagram

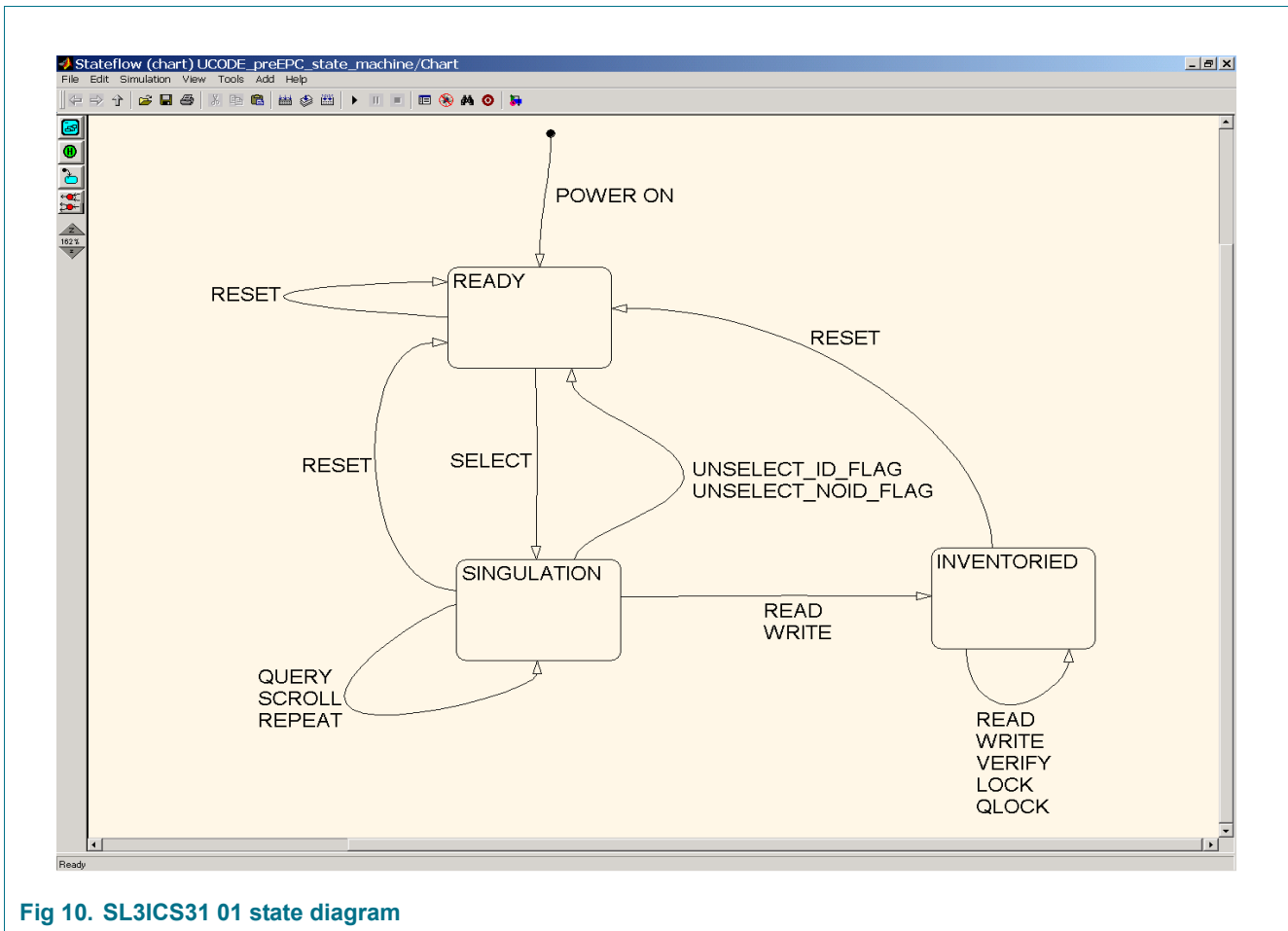

Fig 10. SL3ICS31 01 state diagram

### 7.4 Inventorying tag populations

The inventorying is done by collision arbitration in the following way:

- A reader first uses the SELECT command to place a tag population into the SINGULATION state. This also sets the tags' internal counters COUNT to 0.
- A reader then inventories tags. The reader begins an inventory round by transmitting a QUERY command. Tags receiving a QUERY command in the selected population roll a 2-sided fair die, and reply the SNR if they roll a 0. In case they roll a 1, then increase their counter COUNT by 1.
- If more than one tags replies due to COUNT equal to zero then the reader issues another QUERY command, where tags having COUNT equal to 0 act as described in point 2. Tags having COUNT greater than 0 increase COUNT. For the exception that COUNT is already FFhex, then it stays at FFhex.
- If again more than one tags replies step 3 repeats.
- If all tags roll a 1 and do not reply, then the reader issues a SCROLL command and all counters COUNT decrement and those tags getting a COUNT equal to 0 reply. In general this then means step 3 repeats.

- If only one tag transmits and the SNR is received correctly then the reader sends a READ command to bring the tag in the state INVENTORIED. After handling this tag the reader sends a SCROLL, which in general means that step 3 repeats with the remaining tags.

## 7.5 Accessing individual tags

After singulation of a tag, a reader has the option to access it. Access functions include reading, writing to system or user memory, locking system or user memory. Before executing the command, the tag verifies the SNR sent with the command in order to decide whether it is addressed by the command.

## 7.6 Reader commands and tag replies

### 7.6.1 Command overview

Table 16. Command overview

COMMAND NAME	R	I	D	DESCRIPTION
SELECT	x	x		Command that selects tags in the field to participate in the identification process
UNSELECT_ID_FLAG		x		Command that unselects tags in the field with the ID flag set.
UNSELECT_NOID_FLAG		x		Command that unselects tags in the field with the ID flag cleared.
UNSELECT_NE		x		Command that unselects tags in the field with un-matching data.
QUERY		x		Anticollision command to initiate collision arbitration and after recognized collision
SCROLL		x		Anticollision command after recognized identification or no-response
REPEAT		x		Anticollision command after incorrect response
RESET	x	x	x	Moves all tags in the READY state and clears the ID flag
READ	x	x	x	Reads data of a defined tag from a special address
READ_FLEXIBLE	x	x	x	Reads defined number of bytes from a certain memory address of one tag
VERIFY	x	x	x	Reads data of a defined tag from a special address; typical after a write process
WRITE	x	x	x	Writes data to a special address of one tag
LOCK			x	Locks a special byte of one tag
QLOCK	x	x	x	Queries the lock status of a special byte of one tag

Table 17. State transition table

COMMAND NAME	CODE	PARAMETERS			
SELECT	00 <sub>hex</sub>	ADDRESS	BYTE_MASK	WORD_DATA	
UNSELECT_ID_FLAG	19 <sub>hex</sub>	ADDRESS	BYTE_DATA		
UNSELECT_NOID_FLAG	1A <sub>hex</sub>	ADDRESS	BYTE_DATA		
UNSELECT_NE	05 <sub>hex</sub>	ADDRESS	BYTE_MASK	WORD_DATA	
QUERY	08 <sub>hex</sub>	None			
SCROLL	09 <sub>hex</sub>	None			
REPEAT	15 <sub>hex</sub>	None			
RESET	0A <sub>hex</sub>	None			
READ	0C <sub>hex</sub>	SNR	ADDRESS		
READ_FLEXIBLE	51 <sub>hex</sub>	SNR	ADDRESS	LENGTH	
VERIFY	1D <sub>hex</sub>	SNR	ADDRESS		
WRITE	1B <sub>hex</sub>	SNR	ADDRESS	BYTE_MASK	BLOCK_DATA
LOCK	0F <sub>hex</sub>	SNR	ADDRESS		
QLOCK	11 <sub>hex</sub>	SNR	ADDRESS		

## 7.7 Definition of communication parameters

This chapter defines the used communication parameters for both the reader to tag and tag to reader communication link.

Table 18. Reader to tag link parameters

FIELD NAME	FIELD SIZE
PREAMBLE	various lengths
COMMAND	1 byte
ADDRESS	1 byte
BYTE_MASK	1 byte
SNR	8 bytes
WORD_DATA	8 bytes
BYTE_DATA	1 byte
BLOCK_DATA	4 bytes
CRC	2 bytes
LENGTH	1 byte

Table 19. Tag to reader link parameters

FIELD NAME	FIELD SIZE	VALUE
ACKNOWLEDGE	1 byte	00 <sub>hex</sub>
ACKNOWLEDGE_NOK	1 byte	00 <sub>hex</sub>
ACKNOWLEDGE_OK	1 byte	01 <sub>hex</sub>
ERROR_NOK	1 byte	FE <sub>hex</sub>
ERROR	1 byte	FF <sub>hex</sub>
ERROR_OK	1 byte	FF <sub>hex</sub>
SNR	8 bytes	various values

Table 19. Tag to reader link parameters

FIELD NAME	FIELD SIZE	VALUE
WORD_DATA	8 bytes	various values
BYTE_DATA	1 byte	various values
CRC	2 bytes	various values
FLEXIBLE_DATA	LENGTH + 1 byte	various values

## 7.8 Flags

The SL3ICS31 01 supports 2 flags: ID (Identified) and WRITE\_OK, which are used by several commands.

Table 20. Tag internal flags

NAME	DESCRIPTION
ID	This flag used to indicate that a tag has been identified.
WRITE_OK	This flag is used to indicate a successful WRITE or LOCK command and is checked by VERIFY and QLOCK.

### 7.8.1 ID (Identified)

The tag sets this bit when the tag goes into the IDENTIFIED state and keeps it set unless it loses power. When the ID is set and the tag loses power, then the tag triggers a timer that will reset the ID bit after  $t_{ID}$ .

When the tag goes into the READY state after getting powered again and the ID flag is still set, the timer is reset and ID flag stays set.

When the tag receives the RESET command, then it resets the ID flag immediately.

### 7.8.2 WRITE\_OK

This bit indicates whether a previous write operation was done without any problems.

If WRITE\_OK is set, the last programming cycle of the EEPROM was done properly.

The WRITE\_OK bit is reset by any inadequate EEPROM write cycle or a voltage supply interruption (see Power interruptions). Further, it is reset latest at the begin of the second command following a write access to the EEPROM.

**Remark:** To be absolute sure that the programming process was done correct, the data needs to be verified with an additional read command.

## 7.9 Lockable state machine

This lockable state machine is used to control the possibility of locking bytes in the EEPROM.

The lockable state machine has 2 states, IDLE and LOCKABLE. Initially, the state is IDLE. After any valid READ, READ\_FLEXIBLE, WRITE and QLOCK commands to the tag, the state becomes LOCKABLE, and locks on that dedicated byte are allowed. The specified address (starting address) is saved.

If a LOCK command to the same address of the same tag is received and the state is LOCKABLE, the lock proceeds.

If any other command is received, including a command to another tags, or any command packet has an error, the state returns to IDLE and the lock is no longer allowed.

## 7.10 Select commands

### 7.10.1 SELECT

When receiving a SELECT command, a tag with the appropriate initialized system memory sets its internal counter COUNT to 0, reads its SNR, sends back the SNR and goes into the SINGULATION state.

When receiving a SELECT command, a tag that is in the SINGULATION state sets its internal counter COUNT to 0, reads its SNR, sends back the SNR and stays in the SINGULATION state.

In all other cases the tag will not send any reply.

**Table 21. Command sequence**

PREAMBLE	Command	ADDRESS	BYTE_MASK	WORD_DATA	CRC
	00 <sub>hex</sub>	00 <sub>hex</sub>	C0 <sub>hex</sub>	EF <sub>hex</sub> 04 <sub>hex</sub> 00 <sub>hex</sub> 00 <sub>hex</sub> 00 <sub>hex</sub> 00 <sub>hex</sub> 00 <sub>hex</sub> 00 <sub>hex</sub>	CRC

**Table 22. Response sequence in case the tag meets the criteria for a reply**

RETURN PREAMBLE	SNR	CRC
-----------------	-----	-----

### 7.10.2 UNSELECT\_ID\_FLAG

When receiving UNSELECT\_ID\_FLAG command, a tag which is in the SINGULATION state and the ID flag set, goes into the state READY and will not reply. In case the ID flag is not set, the tag sets its internal counter COUNT to logic 0 and sends back the SNR and stays in the state SINGULATION.

In all other cases the tag will not send any reply.

**Table 23. Command sequence**

PREAMBLE	Command	BYTE_MASK	BYTE_DATA	CRC
	19 <sub>hex</sub>	01 <sub>hex</sub>	01 <sub>hex</sub>	CRC

**Table 24. Response sequence in the ID flag is not**

RETURN PREAMBLE	SNR	CRC
-----------------	-----	-----

### 7.10.3 UNSELECT\_NOID\_FLAG

When receiving a UNSELECT\_NOID\_FLAG command, a tag which is in the SINGULATION state and having the ID flag not set, goes into the state READY and will not reply. In case the ID flag is set, the tag sets its internal counter COUNT to logic 0, sends back the SNR and stays in the state SINGULATION.

In all other cases the tag will not send any reply.

Table 25. Command sequence

PREAMBLE	Command	BYTE_MASK	BYTE_DATA	CRC
	19 <sub>hex</sub>	01 <sub>hex</sub>	00 <sub>hex</sub>	CRC

Table 26. Response sequence in case the ID flag is set:

RETURN PREAMBLE	SNR	CRC
-----------------	-----	-----

#### 7.10.4 UNSELECT\_NE

When receiving a UNSELECT\_NE command, a tag which is in the SINGULATION state and the WORD\_DATA did not match the memory content beginning at the specified ADDRESS, goes into the state READY and will not reply. In case the WORD\_DATA matches the memory content beginning at the specified ADDRESS, the tag sets its internal counter COUNT to logic 0, sends back the SNR and stays in the state SINGULATION.

In all other cases the tag will not send any reply.

Table 27. Command sequence

PREAMBLE	Command	ADDRESS	BYTE_MASK	WORD_DATA	CRC

Table 28. Response sequence in case of non-meeting the unselection criteria

RETURN PREAMBLE	SNR	CRC
-----------------	-----	-----

### 7.11 Inventory commands

Inventory commands are used to run the collision arbitration protocol.

#### 7.11.1 QUERY

The identification algorithm uses QUERY when more than one tag tried to identify itself at the same time. Some tags back off and some tags retransmit.

In case its internal counter COUNT is not zero or the random generator result is 1, then COUNT is increased by 1, unless it is FF<sub>hex</sub>.

If the resulting COUNT value is 0, then the tag reads its SNR and sends it back.

Table 29. Command sequence

PREAMBLE	Command	CRC
	08 <sub>hex</sub>	CRC

Table 30. Response sequence in case of COUNTER equals zero

RETURN PREAMBLE	SNR	CRC
-----------------	-----	-----



### 7.11.2 SCROLL

SCROLL initiates identification of the next set of tags. It is used in two cases:

When all tags receiving QUERY backed off and did not transmit, SCROLL causes those same tags to transmit again.

After any read or write command moved an identified tag to INVENTORIED, SCROLL causes the next subset of selected but unidentified tags to transmit.

- In case its internal counter COUNT is not zero, it will be decreased by 1.
- If the resulting COUNT value is 0, then the tag reads its SNR and sends it back.

**Table 31. Command sequence**

PREAMBLE	Command	CRC
	09 <sub>hex</sub>	CRC

**Table 32. Response sequence in case of COUNTER equals zero**

RETURN PREAMBLE	SNR	CRC
-----------------	-----	-----

### 7.11.3 REPEAT

The identification algorithm uses REPEAT when only one tag transmitted but the SNR was received in error. The tag that transmitted resends its SNR.

If the COUNT value is 0, then the tag reads its SNR and sends it back.

**Table 33. Command sequence**

PREAMBLE	Command	CRC
	15 <sub>hex</sub>	CRC

**Table 34. Response sequence in case of COUNTER equals zero**

RETURN PREAMBLE	SNR	CRC
-----------------	-----	-----

### 7.11.4 RESET

When receiving an RESET command a tag goes into the READY state and resets the ID flag.

The tag will not send any response.

**Table 35. Command sequence**

PREAMBLE	Command	CRC
	0A <sub>hex</sub>	CRC

## 7.12 Access commands

Access commands are used to read or write data from or to the memory.

### 7.12.1 READ

When receiving the READ command, the tag compares the sent SNR with its SNR. In case they are equal, the tag moves to or stays in the INVENTORIED state, reads the 8

byte memory content beginning at the specified ADDRESS and sends back its content in the response.

Further, the tag marks the byte at ADDRESS lockable in the lockable state machine.

In all other cases the tag will not send any reply.

**Table 36. Command sequence**

PREAMBLE	Command	SNR	ADDRESS	CRC
	0C <sub>hex</sub>			

**Table 37. Response sequence in case of matching SNR:**

RETURN PREAMBLE	WORD_DATA	CRC
-----------------	-----------	-----

### 7.12.2 READ\_FLEXIBLE

When receiving the READ\_FLEXIBLE command, the tag compares the sent SNR with its SNR. In case they are equal, the tag moves to or stays in the INVENTORIED state, reads as many bytes as specified in

LENGTH of the memory content beginning at the specified ADDRESS and sends back its content in the response. The number given in LENGTH is one less than the number of byte-blocks that will be transmitted.

Further, the tag marks the byte at ADDRESS lockable in the lockable state machine.

In all other cases the tag will not send any reply.

**Table 38. Command sequence**

PREAMBLE	Command	SNR	ADDRESS	LENGTH	CRC
	51 <sub>hex</sub>				

**Table 39. Response sequence in case of matching SNR**

RETURN PREAMBLE	FLEXIBLE_DATA	CRC
-----------------	---------------	-----

### 7.12.3 READ\_VERIFY

When receiving the READ\_VERIFY command, the tag compares the sent SNR with its SNR. In case the SNRs are equal the WRITE\_OK flag is set, the tag moves to the INVENTORIED state, reads the 4-byte memory content at the specified address and send back its content in the response.

In all other cases the tag will not send any reply.

BYTE\_MASK of the command

ADDRESS bit of BYTE\_MASK to select whether byte should be written

[ADDRESS+0] B7

[ADDRESS+1] B6

[ADDRESS+2] B5

[ADDRESS+3] B4

**Table 40. Command sequence**

PREAMBLE	Command	SNR	ADDRESS	CRC
	1D <sub>hex</sub>			

**Table 41. Response sequence in case of matching SNR and WRITE\_OK**

RETURN PREAMBLE	BYTE_DATA	CRC
-----------------	-----------	-----

### 7.12.4 WRITE

When receiving the WRITE command, the tag compares the sent SNR with its SNR. In case the SNRs are equal, the tag moves to the INVENTORIED state, read the lock information for the 4 bytes on the specified memory content beginning at the specified address. In case one of the 4 bytes is locked, it sends back the ERROR response. In case unlocked, it sends back the ACKNOWLEDGE and programs the data into the specified memory.

Executing WRITE, a tag only writes those bytes that are selected by the BYTE\_MASK.

In case the write access was successful, the tag sets the WRITE\_OK bit. Otherwise, it resets it.

The starting address for the WRITE command must be on a 4-byte page boundary.

**Table 42. Command sequence**

PREAMBLE	Command	SNR	ADDRESS	BYTE_MASK	BLOCK_DATA	CRC	WAIT
	1B <sub>hex</sub>						

**Table 43. Response sequence in case of matching SNR but any locked byte**

RETURN PREAMBLE	ERROR	CRC
-----------------	-------	-----

**Table 44. Response sequence in case of matching SNR and all unlocked byte**

RETURN PREAMBLE	ACKNOWLEDGE	CRC	EEPROM programming process
-----------------	-------------	-----	----------------------------

### 7.12.5 LOCK

When receiving a LOCK command, a tag that is in the INVENTORIED state reads its SNR and compares it with the SNR sent by the reader. In case the SNRs are equal and the byte at ADDRESS is marked lockable, then the tag sends back an ACKNOWLEDGE and programs the lock bit of the specified memory address. In case the ADDRESS is not in the valid address range, or it is not marked as lockable, then the tag sends back the ACKNOWLEDGE\_NOK.

In all other cases the tag will not send any reply.

**Table 45. Command sequence**

PREAMBLE	Command	SNR	ADDRESS	CRC	WAIT
0F <sub>hex</sub>					

**Table 46. Response sequence in case of matching SNR and lockable byte**

RETURN PREAMBLE	ACKNOWLEDGE	CRC	EEPROM programming process		
-----------------	-------------	-----	----------------------------	--	--

**Table 47. Response sequence in case of matching SNR but unlockable byte**

RETURN PREAMBLE	ACKNOWLEDGE_NOK	CRC			
-----------------	-----------------	-----	--	--	--

### 7.12.6 QLOCK

When receiving a QLOCK command, a tag reads its SNR and compares it with the SNR sent by the reader. In case the SNRs are equal the tag moves into the INVENTORIED state. Further, the tag reads the lock bit for the memory byte at ADDRESS. In case the memory is not locked, then it responds ACKNOWLEDGE\_OK if WRITE\_OK is set and ACKNOWLEDGE\_NOK if WRITE\_OK is cleared. In case that this memory is locked, then it responds ERROR\_OK if WRITE\_OK is set and ERROR\_NOK if WRITE\_OK is cleared.

Further, the tag marks the byte at ADDRESS lockable in the lockable state machine.

In all other cases the tag will not send any reply.

**Table 48. Command sequence**

PREAMBLE	Command	SNR	ADDRESS	CRC
11 <sub>hex</sub>				

**Table 49. Response sequence in case of matching SNR, WRITE\_OK set and unlocked byte**

RETURN PREAMBLE	ACKNOWLEDGE_OK	CRC			
-----------------	----------------	-----	--	--	--

**Table 50. Response sequence in case of matching SNR, WRITE\_OK cleared and unlocked byte**

RETURN PREAMBLE	ACKNOWLEDGE_NOK	CRC			
-----------------	-----------------	-----	--	--	--

**Table 51. Response sequence in case of matching SNR, WRITE\_OK set and locked byte**

RETURN PREAMBLE	ERROR_OK	CRC			
-----------------	----------	-----	--	--	--

**Table 52. Response sequence in case of matching SNR, WRITE\_OK cleared and locked byte**

RETURN PREAMBLE	ERROR_NOK	CRC			
-----------------	-----------	-----	--	--	--

### 7.12.7 Exception handling for fast tag to reader communication

If "10 10 10 10 10 10 10 10 10 10 11 01 11 00 10 1" is used as PREAMBLE in the reader to tag link to use the high tag to reader link datarate (4 times the reader to tag link datarate) the following deviations have to be considered:

Within the responses of the tag (ACKNOWLEDGE, ACKNOWLEDGE\_NOK, ACKNOWLEDGE\_OK, ERROR\_NOK, ERROR, ERROR\_OK) to the following commands: WRITE, LOCK, QLOCK the data byte returned by the tag does not contain the information used for CRC calculation. Therefore it shall be ignored but only the CRC should be evaluated.

Therefore the returned information has the following meaning described in [Table 53](#).

**Table 53. Tag responses in the 4x tag to reader link mode<sup>[1][2]</sup>**

RESPONSE NAME	RESPONSE SIZE / BYTE		TRANSMITTED VALUE	
	DATA	CRC	DATA	CRC
ACKNOWLEDGE	1	2	XX <sub>hex</sub>	1E0F <sub>hex</sub>
ACKNOWLEDGE_NOK	1	2	XX <sub>hex</sub>	1E0F <sub>hex</sub>
ACKNOWLEDGE_OK	1	2	XX <sub>hex</sub>	0E2E <sub>hex</sub>
ERROR_NOK	1	2	XX <sub>hex</sub>	00FF <sub>hex</sub>
ERROR	1	2	XX <sub>hex</sub>	00FF <sub>hex</sub>
ERROR_OK	1	2	XX <sub>hex</sub>	10DE <sub>hex</sub>

[1] The transmitted CRC value corresponds to the data according the appropriate response.

[2] XX hex indicated values that are not according the appropriate response and do not carry any useful respond information.

## 8. Recommended operating conditions

### 8.1 Operating Distances

RFID tags based on the UCODE EPC 1.19 / SL3ICS31 01 silicon may achieve operating distances according the following formula:

$$P_{tag} = EIRP_{tag} \left( \frac{\lambda}{4\pi R} \right)^2$$

$$R_{max} = \sqrt{\frac{EIRP_{tag} \lambda^2}{(4\pi)^2 P_{tag}}}$$

- P<sub>tag</sub> Minimum required RF power for the tag
- G<sub>tag</sub> Gain of the tag antenna
- EIRP Transmitted RF power
- λ Wavelength
- R<sub>max</sub> Maximum achieved operating distance for a lossless, matched 1/2-dipole.

**Table 54. Operating distances for UCODE EPC 1.19 based tags and labels in released frequency bands**

FREQUENCY RANGE	REGION	AVAILABLE POWER	CALCULATED READ DISTANCE SINGLE ANTENNA <sup>(8)(9)</sup>	UNIT
868.4 to 868.65 MHz (UHF)	Europe <sup>(1)</sup>	0.5 W ERP	4.0	m
865.5 to 867.6 MHz (UHF)	Europe <sup>(2)</sup>	2 W ERP	8.0	m
902 to 928 MHz (UHF)	America <sup>(3)</sup>	4 W EIRP	8.4	m
860 to 960 MHz (UHF)	Others <sup>(4)</sup>			m
2.400 GHz to 2.4835 GHz	Europe <sup>(5)</sup>	0.5 W EIRP outdoor	0.6	m
2.400 GHz to 2.4835 GHz	Europe <sup>(5)</sup>	4 W EIRP indoor	1.8	m
2.400 GHz to 2.4835 GHz	America <sup>(6)</sup>	4 W EIRP	1.8	m
2.400 GHz to 2.4835 GHz	Others <sup>(7)</sup>			m

- Current CEPT/ETSI regulations [CEPT1], [ETSI1].
- Proposal for future CEPT/ETSI regulations. [ETSI3]

- FCC regulation [FCC1].
- In many other countries regulations either similar to FCC or CEPT/ETSI may apply.
- Current CEPT/ETSI regulations [CEPT2], [ETSI2].
- FCC regulation [FCC1].
- In many other countries regulations either similar to FCC or CEPT/ETSI may apply.
- These distances are typical values for general tags and labels. A special tag antenna design or reflection could achieve higher values.
- Practical usable read distance values might be notable lower, strongly depending on application set-up, damping by environment materials and the quality of the matching between tag antenna and chip impedance.

The maximum write distance is around 70% of the read distance.

## 9. Characteristics

$V_{DD} > V_{DDmin}$ ;  $V_{SS} = 0\text{ V}$ ;  $T_{amb} = -40\text{ to }85\text{ }^\circ\text{C}$ ; all voltages with respect to  $V_{SS}$  unless otherwise specified.

**Table 55. DC Characteristics**

SYMBOL	PARAMETER	CONDITIONS	MIN	TYP	MAX	UNIT
$V_{RFP,min}$	minimum supply voltage range for communication except EEPROM	see note[1]	1.1 5		1.55	V
$V_{RFP,write}$	write minimum supply voltage for EEPROM programming	see note[1]	2.1 0		2.40	V

[1] The measured operating voltage is the open-circuit voltage of a source with a 50 W output impedance.

$V_{DD} > V_{DDmin}$ ;  $V_{SS} = 0\text{ V}$ ;  $T_{amb} = -40\text{ to }85\text{ }^\circ\text{C}$ ; all voltages with respect to  $V_{SS}$  unless otherwise specified.

**Table 56. AC Characteristics**

SYMBOL	PARAMETER	CONDITIONS	MIN	TYP	MAX	UNIT
$t_{ID}$	Storage time for ID flag	IC temperature: 0 to 50°C	4	-	-	s
		IC temperature: -30°C to 60°C	2	-	-	s
$t_{EEwrite}$	Required time for programming the EEPROM		13.3	-	-	ms
$t_{NN}$	Power interruptions, no notice		-	-	0.5	μs
$t_{SD}$	Power interruptions, start of demodulation		0.5	-	250	μs

## 10. Abbreviations

**Table 57. Abbreviations**

ABBREVIATION	DEFINITION
CRC	Cyclic Redundancy Check
EEPROM	Electrically Erasable and Programmable Read Only Memory
EPC	Electronic Product Code (containing Header, Domain Manager, Object Class and Serial Number)
IC	Integrated Circuit
LSB	Least Significant Bit or Byte
MSB	Most Significant Bit or Byte
NRZ	Non-return to zero coding
RF	Radio Frequency
SNR	Memory content that is stored on the chip at address 00 <sub>hex</sub> - 07 <sub>hex</sub> (containing the Serial Number of the EPC)
XX <sub>hex</sub>	Value in hexadecimal notation

## 11. References

- [1] [CEPT1]: CEPT REC 70-03 Annex 1
- [2] [CEPT2]: CEPT REC 70-03 Annex 11
- [3] [ETSI1]: ETSI EN 330 220-1
- [4] [ETSI2]: ETSI EN 330 440-1
- [5] [ETSI3]: Draft 4c ETSI EN 302 208-1 V<1.1.1> (2002-Electromagnetic compatibility And Radio spectrum Matters (ERM) Radio Frequency Identification Equipment operating in the band 865 - MHz to 868 MHz with power levels up to 2 W Part 1: Technical characteristics and test methods.
- [6] [FCC1]: FCC Part 15 Section 247



## 12. Revision history

Table 58. Revision history

Document ID	Release date	Data sheet status	Change notice	Supersedes
093130	June 2007	Product data sheet		2.0
Modifications:				
				<ul style="list-style-type: none"><li>• The format of this data sheet has been redesigned to comply with the new identity guidelines of NXP Semiconductors.</li><li>• Legal texts have been adapted to the new company name where appropriate.</li></ul>
093120	July 2004	Preliminary data sheet		1.4
093114	May 2004	Objective data sheet		1.2
093112	Dezember 2003	Objective data sheet		

## 13. Legal information

### 13.1 Data sheet status

Document status <sup>[1][2]</sup>	Product status <sup>[3]</sup>	Definition
Objective [short] data sheet	Development	This document contains data from the objective specification for product development.
Preliminary [short] data sheet	Qualification	This document contains data from the preliminary specification.
Product [short] data sheet	Production	This document contains the product specification.

[1] Please consult the most recently issued document before initiating or completing a design.

[2] The term 'short data sheet' is explained in section "Definitions".

[3] The product status of device(s) described in this document may have changed since this document was published and may differ in case of multiple devices. The latest product status information is available on the Internet at URL <http://www.nxp.com>.

### 13.2 Definitions

**Draft** — The document is a draft version only. The content is still under internal review and subject to formal approval, which may result in modifications or additions. NXP Semiconductors does not give any representations or warranties as to the accuracy or completeness of information included herein and shall have no liability for the consequences of use of such information.

**Short data sheet** — A short data sheet is an extract from a full data sheet with the same product type number(s) and title. A short data sheet is intended for quick reference only and should not be relied upon to contain detailed and full information. For detailed and full information see the relevant full data sheet, which is available on request via the local NXP Semiconductors sales office. In case of any inconsistency or conflict with the short data sheet, the full data sheet shall prevail.

### 13.3 Disclaimers

**General** — Information in this document is believed to be accurate and reliable. However, NXP Semiconductors does not give any representations or warranties, expressed or implied, as to the accuracy or completeness of such information and shall have no liability for the consequences of use of such information.

**Right to make changes** — NXP Semiconductors reserves the right to make changes to information published in this document, including without limitation specifications and product descriptions, at any time and without notice. This document supersedes and replaces all information supplied prior to the publication hereof.

**Suitability for use** — NXP Semiconductors products are not designed, authorized or warranted to be suitable for use in medical, military, aircraft, space or life support equipment, nor in applications where failure or malfunction of a NXP Semiconductors product can reasonably be expected to result in personal injury, death or severe property or environmental damage. NXP Semiconductors accepts no liability for inclusion and/or use of NXP Semiconductors products in such equipment or applications and therefore such inclusion and/or use is at the customer's own risk.

**Applications** — Applications that are described herein for any of these products are for illustrative purposes only. NXP Semiconductors makes no representation or warranty that such applications will be suitable for the specified use without further testing or modification.

**Limiting values** — Stress above one or more limiting values (as defined in the Absolute Maximum Ratings System of IEC 60134) may cause permanent damage to the device. Limiting values are stress ratings only and operation of the device at these or any other conditions above those given in the Characteristics sections of this document is not implied. Exposure to limiting values for extended periods may affect device reliability.

**Terms and conditions of sale** — NXP Semiconductors products are sold subject to the general terms and conditions of commercial sale, as published at <http://www.nxp.com/profile/terms>, including those pertaining to warranty, intellectual property rights infringement and limitation of liability, unless explicitly otherwise agreed to in writing by NXP Semiconductors. In case of any inconsistency or conflict between information in this document and such terms and conditions, the latter will prevail.

**No offer to sell or license** — Nothing in this document may be interpreted or construed as an offer to sell products that is open for acceptance or the grant, conveyance or implication of any license under any copyrights, patents or other industrial or intellectual property rights.

### 13.4 Licenses

#### Purchase of NXP <xxx> components

<License statement text> (replace this table by text inset t001lic<1nn>)

### 13.5 Patents

Notice is herewith given that the subject device uses one or more of the following patents and that each of these patents may have corresponding patents in other jurisdictions.

<Patent ID> — owned by <Company name> (replace by text inset t001pat<1nn>)

### 13.6 Trademarks

Notice: All referenced brands, product names, service names and trademarks are the property of their respective owners.

**UCODE** — is a trademark of NXP B.V.

## 14. Contact information

For additional information, please visit: <http://www.nxp.com>

For sales office addresses, send an email to: [salesaddresses@nxp.com](mailto:salesaddresses@nxp.com)

15. Tables

Table 1.	.....	4	Table 33.	Command sequence	.....	25	
Table 2.	Definition of tag RESYNC	.....	5	Table 34.	Response sequence in case of COUNTER equals zero	.....	25
Table 3.	Manchester reader to tag link bit duty cycle tolerance	.....	7	Table 35.	Command sequence	.....	25
Table 4.	RF envelope parameters	.....	8	Table 36.	Command sequence	.....	26
Table 5.	Definition of read to tag PREAMBLE	.....	9	Table 37.	Response sequence in case of matching SNR	.....	26
Table 6.	FM0 tag to reader link bit duty cycle tolerance	.....	10	Table 38.	Command sequence	.....	26
Table 7.	Definition of tag to reader preamble	.....	10	Table 39.	Response sequence in case of matching SNR	.....	26
Table 8.	FM0 Reader to tag link datarates	.....	10	Table 40.	Command sequence	.....	27
Table 9.	Maximum reader settling time	.....	12	Table 41.	Response sequence in case of matching SNR and WRITE_OK	.....	27
Table 10.	Timing limits	.....	13	Table 42.	Command sequence	.....	27
Table 11.	Tag reaction on power interruptions	.....	13	Table 43.	Response sequence in case of matching SNR but any locked byte	.....	27
Table 12.	CRC definition	.....	14	Table 44.	Response sequence in case of matching SNR and all unlocked byte	.....	27
Table 13.	Practical example of CRC calculation for a 'SUCCESS' command in the reader	.....	15	Table 45.	Command sequence	.....	28
Table 14.	Practical example of CRC checking for a 'SUCCESS' command in the tag	.....	16	Table 46.	Response sequence in case of matching SNR and lockable byte	.....	28
Table 15.	SL3ICS31 memory	.....	17	Table 47.	Response sequence in case of matching SNR but unlockable byte	.....	28
Table 16.	Command overview	.....	20	Table 48.	Command sequence	.....	28
Table 17.	State transition table	.....	21	Table 49.	Response sequence in case of matching SNR, WRITE_OK set and unlocked byte	.....	28
Table 18.	Reader to tag link parameters	.....	21	Table 50.	Response sequence in case of matching SNR, WRITE_OK cleared and unlocked byte	.....	28
Table 19.	Tag to reader link parameters	.....	21	Table 51.	Response sequence in case of matching SNR, WRITE_OK set and locked byte	.....	28
Table 20.	Tag internal flags	.....	22	Table 52.	Response sequence in case of matching SNR, WRITE_OK cleared and locked byte	.....	28
Table 21.	Command sequence	.....	23	Table 53.	Tag responses in the 4x tag to reader link mode <sup>[1][2]</sup>	.....	29
Table 22.	Response sequence in case the tag meets the criteria for a reply	.....	23	Table 54.	Operating distances for UCODE EPC 1.19 based tags and labels in released frequency bands	.....	30
Table 23.	Command sequence	.....	23	Table 55.	DC Characteristics	.....	31
Table 24.	Response sequence in the ID flag is not	.....	23	Table 56.	AC Characteristics	.....	31
Table 25.	Command sequence	.....	24	Table 57.	Abbreviations	.....	32
Table 26.	Response sequence in case the ID flag is set	.....	24	Table 58.	Revision history	.....	33
Table 27.	Command sequence	.....	24				
Table 28.	Response sequence in case of non-meeting the unselection criteria	.....	24				
Table 29.	Command sequence	.....	24				
Table 30.	Response sequence in case of COUNTER equals zero	.....	24				
Table 31.	Command sequence	.....	25				
Table 32.	Response sequence in case of COUNTER equals zero	.....	25				

16. Figures

Fig 1.	Tag IC Block Diagram	.....	3	Fig 6.	Example of a reader to tag link sequence	.....	11
Fig 2.	Reader to tag modulation	.....	6	Fig 7.	Example of a tag to reader link sequence	.....	12
Fig 3.	Manchester symbols	.....	7	Fig 8.	Example of a reader to tag link sequence	.....	13
Fig 4.	Reader to tag RF envelope	.....	8	Fig 9.	Example of a reader to tag link sequence	.....	14
Fig 5.	FM0 symbols and sequences	.....	9	Fig 10.	SL3ICS31 01 state diagram	.....	19

continued >>

## 17. Contents

<b>1</b>	<b>General description</b> . . . . .	<b>1</b>	7.2.3.1	Supported EPC types . . . . .	18
<b>2</b>	<b>Features</b> . . . . .	<b>1</b>	7.3	Tag state diagram . . . . .	19
2.1	RF interface features . . . . .	1	7.4	Inventoring tag populations . . . . .	19
2.2	Memory features . . . . .	1	7.5	Accessing individual tags . . . . .	20
2.3	Security features . . . . .	1	7.6	Reader commands and tag replies . . . . .	20
2.4	Air interface standards . . . . .	2	7.6.1	Command overview . . . . .	20
<b>3</b>	<b>Ordering information</b> . . . . .	<b>2</b>	7.7	Definition of communication parameters . . . . .	21
<b>4</b>	<b>Block diagram</b> . . . . .	<b>3</b>	7.8	Flags . . . . .	22
<b>5</b>	<b>Function description</b> . . . . .	<b>4</b>	7.8.1	ID (Identified) . . . . .	22
5.1	Power transfer . . . . .	4	7.8.2	WRITE_OK . . . . .	22
5.2	Operation frequency . . . . .	4	7.9	Lockable state machine . . . . .	22
5.3	Data transfer . . . . .	4	7.10	Select commands . . . . .	23
5.3.1	Reader to tag link . . . . .	4	7.10.1	SELECT . . . . .	23
5.3.2	Tag to reader link . . . . .	4	7.10.2	UNSELECT_ID_FLAG . . . . .	23
<b>6</b>	<b>Physical layer and signaling</b> . . . . .	<b>5</b>	7.10.3	UNSELECT_NOID_FLAG . . . . .	23
6.1	Reader to tag communication . . . . .	5	7.10.4	UNSELECT_NE . . . . .	24
6.1.1	Modulation . . . . .	6	7.11	Inventory commands . . . . .	24
6.1.2	Data Coding . . . . .	7	7.11.1	QUERY . . . . .	24
6.1.3	RF Envelope . . . . .	8	7.11.2	SCROLL . . . . .	25
6.1.4	Preamble . . . . .	9	7.11.3	REPEAT . . . . .	25
6.2	Tag to reader communication . . . . .	9	7.11.4	RESET . . . . .	25
6.2.1	Modulation and data coding . . . . .	9	7.12	Access commands . . . . .	25
6.2.1.1	Baseband FM0 . . . . .	9	7.12.1	READ . . . . .	25
6.2.1.2	FM0 Preamble . . . . .	10	7.12.2	READ_FLEXIBLE . . . . .	26
6.2.2	Data rates . . . . .	10	7.12.3	READ_VERIFY . . . . .	27
6.3	Link timing . . . . .	10	7.12.4	WRITE . . . . .	27
6.3.1	Reader to tag link . . . . .	10	7.12.5	LOCK . . . . .	28
6.3.2	Tag to reader link . . . . .	12	7.12.6	QLOCK . . . . .	28
6.3.3	Response time . . . . .	12	7.12.7	Exception handling for fast tag to reader communication . . . . .	29
6.3.4	Regeneration time . . . . .	12	<b>8</b>	<b>Recommended operating conditions</b> . . . . .	<b>30</b>
6.3.5	Start-up time . . . . .	13	8.1	Operating Distances . . . . .	30
6.3.6	Power interruptions . . . . .	13	<b>9</b>	<b>Characteristics</b> . . . . .	<b>31</b>
6.4	Bit and byte ordering . . . . .	14	<b>10</b>	<b>Abbreviations</b> . . . . .	<b>32</b>
6.5	Data integrity . . . . .	14	<b>11</b>	<b>References</b> . . . . .	<b>32</b>
6.6	CRC definition . . . . .	14	<b>12</b>	<b>Revision history</b> . . . . .	<b>33</b>
6.6.1	CRC Algorithm . . . . .	15	<b>13</b>	<b>Legal information</b> . . . . .	<b>34</b>
6.6.2	CRC calculations example . . . . .	15	13.1	Data sheet status . . . . .	34
<b>7</b>	<b>TAG identification and transaction</b> . . . . .	<b>16</b>	13.2	Definitions . . . . .	34
7.1	Tag overview . . . . .	17	13.3	Disclaimers . . . . .	34
7.1.1	State and flags . . . . .	17	13.4	Licenses . . . . .	34
7.1.1.1	Ready . . . . .	17	13.5	Patents . . . . .	34
7.1.1.2	Singulation . . . . .	17	13.6	Trademarks . . . . .	34
7.1.1.3	Inventoried . . . . .	17	<b>14</b>	<b>Contact information</b> . . . . .	<b>34</b>
7.2	Tag memory . . . . .	17	<b>15</b>	<b>Tables</b> . . . . .	<b>35</b>
7.2.1	Reserved memory . . . . .	17	<b>16</b>	<b>Figures</b> . . . . .	<b>36</b>
7.2.2	System memory . . . . .	17			
7.2.3	Memory overview . . . . .	17			

continued >>

17 Contents ..... 36

Please be aware that important notices concerning this document and the product(s) described herein, have been included in section 'Legal information'.



© NXP B.V. 2010. All rights reserved.
For more information, please visit: http://www.nxp.com
For sales office addresses, please send an email to: salesaddresses@nxp.com
Date of release: 6 July 2007
Document identifier: 093130